

Current Transducer HAS 50 .. 600-S

For the electronic measurement of currents: DC, AC, pulsed..., with galvanic separation between the primary circuit and the secondary circuit.



RoHS

$$I_{PN} = 50 \dots 600 \text{ A}$$



Electrical data

Type	Primary nominal rms current	Primary current, measuring range ¹⁾	RoHS since date code
	I_{PN} (A)	I_{PM} (A)	
HAS 50-S	50	±150	45217
HAS 100-S	100	±300	45325
HAS 200-S	200	±600	45166
HAS 300-S	300	±900	45326
HAS 400-S	400	±900	45333
HAS 500-S	500	±900	45201
HAS 600-S	600	±900	45260

U_C	Supply voltage (±5 % ¹⁾)	±15	V
I_C	Current consumption	±15	mA
R_{IS}	Insulation resistance @ 500 V DC	>1000	MΩ
V_{out}	Output voltage (Analog) @ ± I_{PN} , $R_L = 10 \text{ k}\Omega$, $T_A = 25 \text{ }^\circ\text{C}$	±4	V
R_{out}	Output internal resistance approx	100	Ω
R_L	Load resistance ²⁾	>1	kΩ

Accuracy - Dynamic performance data

X	Accuracy @ I_{PN} , $T_A = 25 \text{ }^\circ\text{C}$ (excluding offset)	<±1	% of I_{PN}
ϵ_L	Linearity error ³⁾ (0 .. ± I_{PN})	<±1	% of I_{PN}
V_{OE}	Electrical offset voltage, $T_A = 25 \text{ }^\circ\text{C}$	<±20	mV
V_{OH}	Hysteresis offset voltage @ $I_p = 0$, after an excursion of $1 \times I_{PN}$	<±20	mV
TCV_{OE}	Temperature coefficient of V_{OE}	HAS 50-S <±2 HAS 100 .. 600-S <±1	mV/K
TCV_{out}	Temperature coefficient of V_{out} (% of reading)	<±0.1	%/K
t_r	Step response time to 90 % of I_{PN}	<3	μs
di/dt	di/dt accurately followed	>50	A/μs
BW	Frequency bandwidth (-3 dB) ⁴⁾	DC .. 50	kHz

General data

T_A	Ambient operating temperature	-10 .. +80	°C
T_S	Ambient storage temperature	-25 .. +80	°C
m	Mass approx	60	g
	Standards	EN 50178: 1997 UL 508: 2010	

- Notes:** ¹⁾ Operating at $\pm 12 \text{ V} \leq U_C < \pm 15 \text{ V}$ will reduce the measuring range
²⁾ If the customer uses 1 kΩ of the load resistor, the primary current has to be limited as the nominal; To measure the full defined measuring range, the load resistor should be at minimum 10 kΩ
³⁾ Linearity data exclude the electrical offset
⁴⁾ Please refer to derating curves in the technical file to avoid excessive core heating at high frequency.

Features

- Hall effect measuring principle
- Insulating plastic case made of polycarbonate PBT recognized according to UL 94-V0.

Advantages

- Easy mounting
- Low power consumption
- Small size and space saving
- Only one design for wide current ratings range
- High immunity to external interference.

Applications

- AC variable speed drives
- Static converters for DC motor drives
- Battery supplied applications
- Uninterruptible Power Supplies (UPS)
- Switched Mode Power Supplies (SMPS)
- Power supplies for welding applications.

Application domain

- Industrial.

Current Transducer HAS 50 .. 600-S

Insulation coordination

U_d	Rms voltage for AC insulation test, 50 Hz/1 min	3.6	kV
\hat{U}_w	Impulse withstand voltage 1.2/50 μ s	>6.6	kV
		Min	
d_{cp}	Creepage distance	7.08	mm
d_{cl}	Clearance	6.23	mm
CTI	Comparative tracking index (group IIIa)	275	

Applications examples

According to EN 50178 and IEC 61010-1 standards and following conditions:

- Over voltage category OV 3
- Pollution degree PD2
- Non-uniform field

	EN 50178	IEC 61010-1
$d_{cp}, d_{cl}, \hat{U}_w$	Rated insulation voltage	Nominal voltage
Basic insulation	600 V	600 V
Reinforced insulation	300 V	300 V

Safety

This transducer must be used in limited-energy secondary circuits according to IEC 61010-1.



This transducer must be used in electric/electronic equipment with respect to applicable standards and safety requirements in accordance with the manufacturer's operating instructions.



Caution, risk of electrical shock

When operating the transducer, certain parts of the module can carry hazardous voltage (eg. primary busbar, power supply).

Ignoring this warning can lead to injury and/or cause serious damage.

This transducer is a build-in device, whose conducting parts must be inaccessible after installation.

A protective housing or additional shield could be used.

Main supply must be able to be disconnected.

Dimensions HAS 50 .. 600-S (in mm)

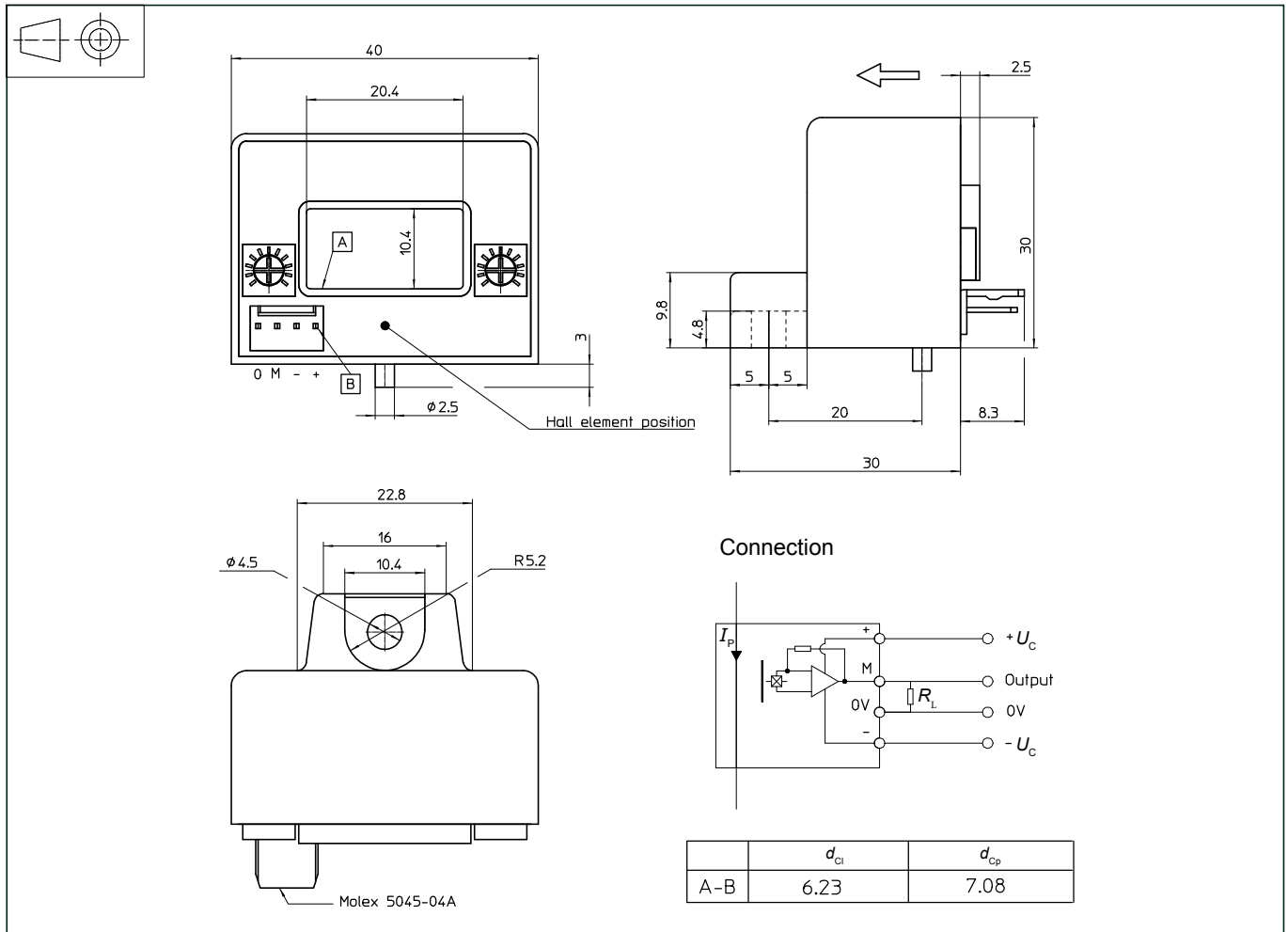

Mechanical characteristics

- General tolerance ± 0.5 mm
- Transducer fastening
1 hole $\phi 4.5$ mm
1 M4 steel screw
Recommended fastening torque 0.75 N·m (± 10 %)
- Connection of secondary Molex 5045-04A

Remarks

- V_{out} is positive when I_p flows in the direction of the arrow.
- Temperature of the primary conductor should not exceed 100 °C.
- Installation of the transducer must be done unless otherwise specified on the datasheet, according to LEM Transducer Generic Mounting Rules. Please refer to LEM document N°ANE120504 available on our Web site: [Products/Product Documentation](#).
- Dynamic performances (di/dt and response time) are best with a single bar completely filling the primary hole.
- This is a standard model. For different versions (supply voltages, turns ratios, unidirectional measurements...), please contact us.