

Rotating Torque Measuring Flange DR-2800 (contactless) with Rated Torque from 50 ... 10000 N·m

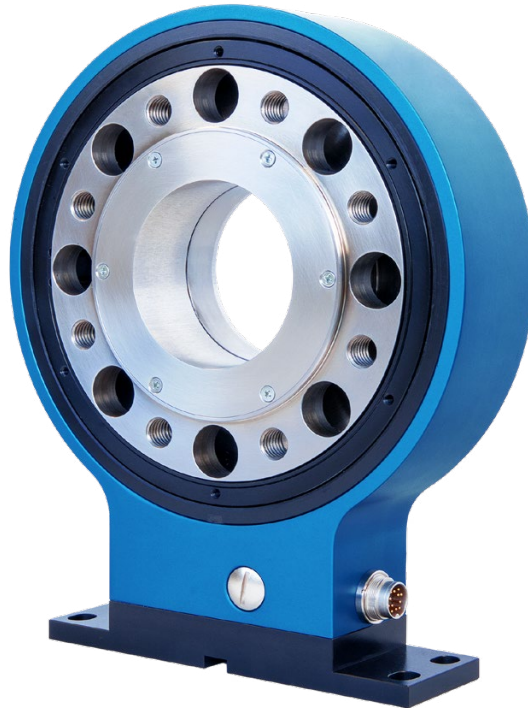

This sensor has a contactless and digital signal transmission from rotor to stator without signal falsification of the measurement data. It is therefore highly accurate and maintenance-free.

Performance Features

- Bearingless torque sensor for e. g. test bench applications
- High accuracy
- Active output $\pm 5V$ (optional $\pm 10V$; 10 kHz ± 5 kHz; 60 kHz ± 30 kHz)
- Integrated speed measurement (optional)
- Speed up to 15000 min⁻¹
- Very short axial length
- High torsional stiffness
- Flange-/flange-solution
- Simple handling and assembly
- Special versions on request

Application

- Research and development
- Process measuring and control technology
- Fully automated machining centres
- Measuring and control devices
- Tool engineering
- Special mechanical engineering

Dimensions in mm

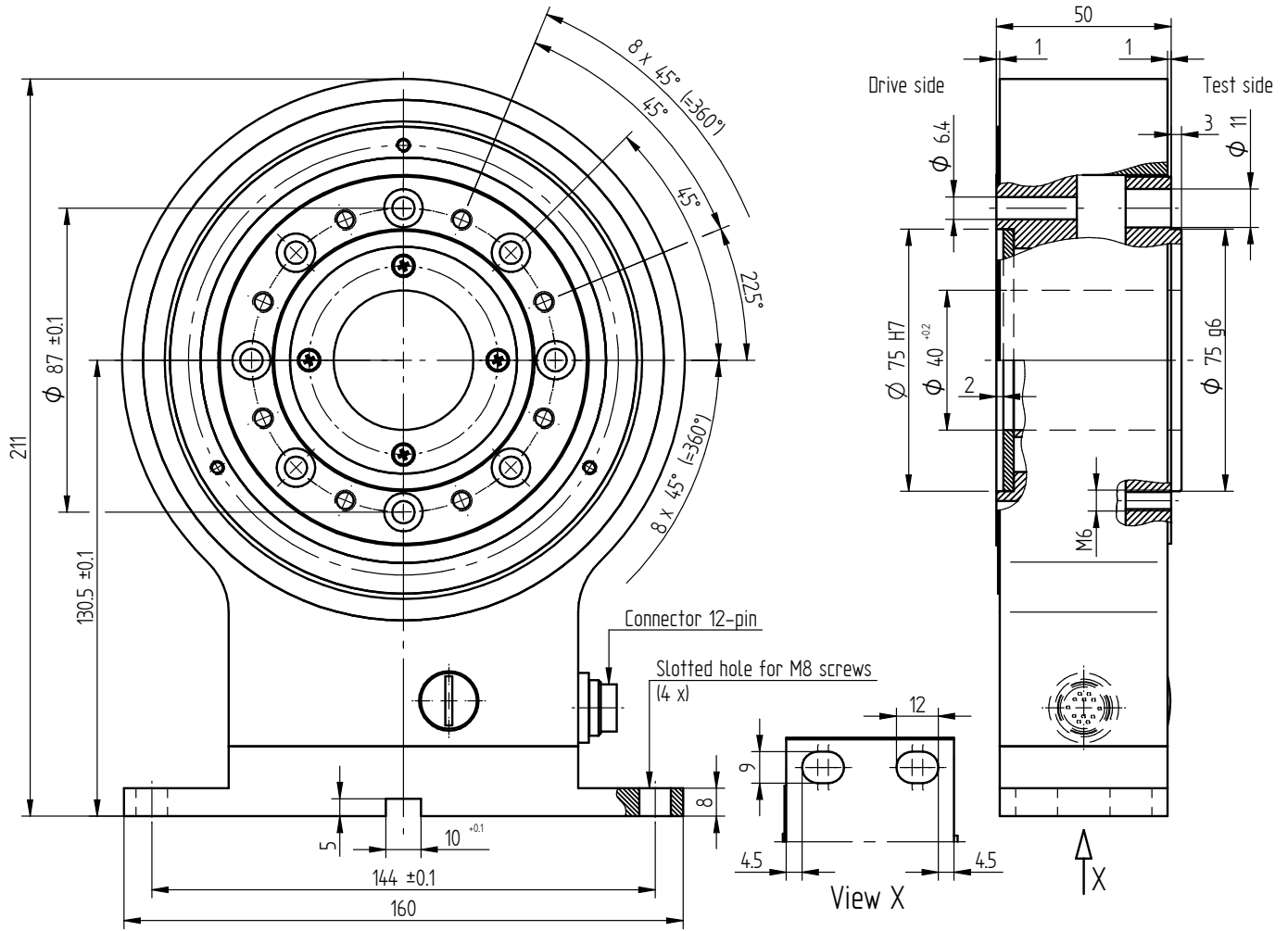

Rated Torque [N·m]	Screws		Weight [kg]
	Tightening Torque [N·m]	Property Class	
50/100	14	10.9	4.1

Dimensions in mm

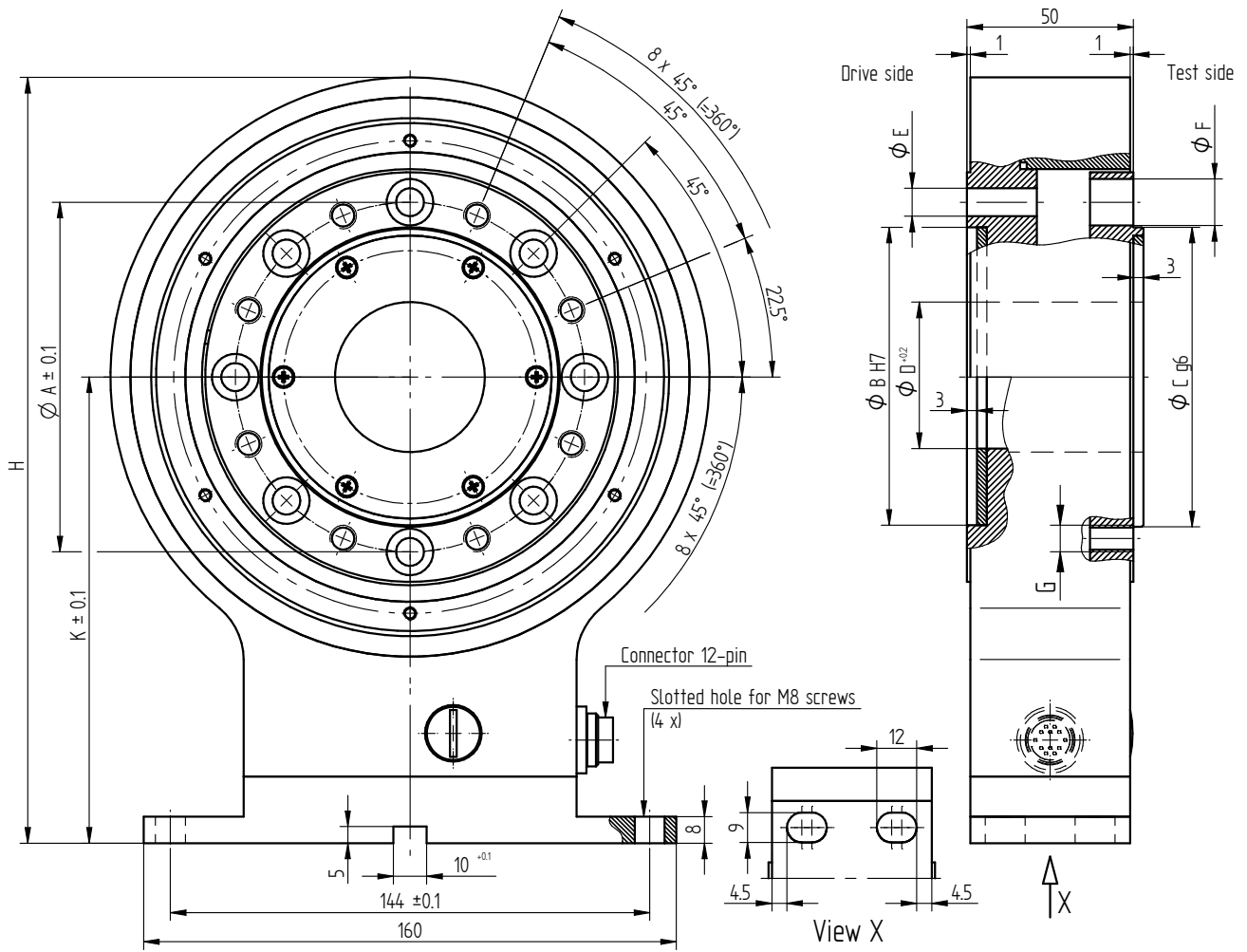

Rated Torque [N·m]	Dimensions [mm]									Screws		Weight [kg]
	$\varnothing A$	$\varnothing B$	$\varnothing C$	$\varnothing D$	$\varnothing E$	$\varnothing F$	G	H	K	Tightening Torque [N·m]	Property Class	
200	105	90	90	45	8.4	14	M8	230	140	35	10.9	4.8
500/1000	133	110	110	70	13	20	M12	250	150	120	10.9	5.4

Dimensions in mm

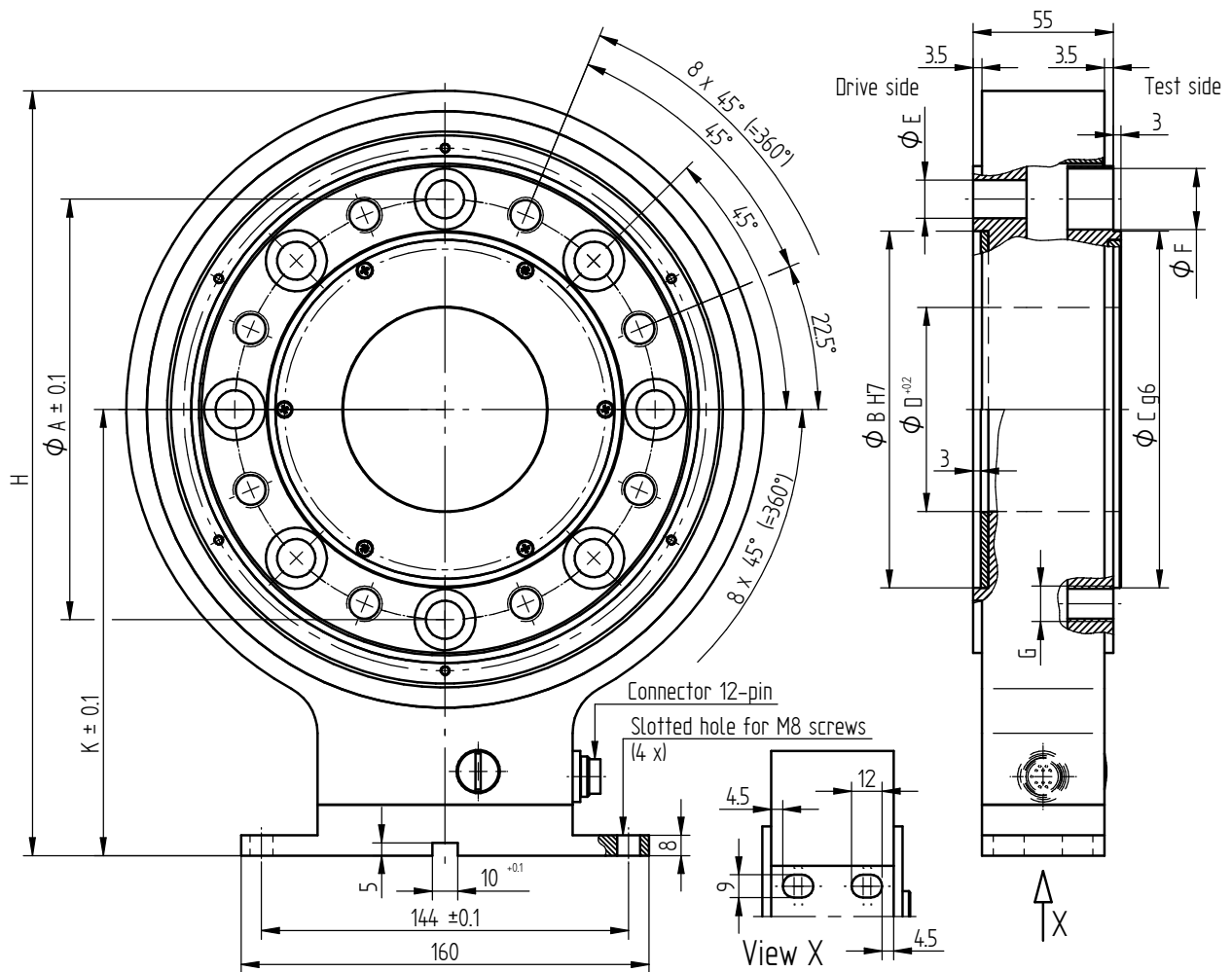

Rated Torque [N·m]	Dimensions [mm]									Screws		Weight [kg]
	ϕA	ϕB	ϕC	ϕD	ϕE	ϕF	G	H	K	Tightening Torque [N·m]	Property Class	
2000	165	140	140	80	15	24	M14	300	175	190	10.9	8.9
5000/10000	206	174	174	100	19	30	M18	360	205	490	12.9	13.3

Connection Assignment

12-pin	DR-2800	Series 581
Pin A	NC	-
Pin B	NC	-
Pin C	Signal (+)	$\pm 5V (\pm 10V)$
Pin D	Signal (GND)	0V
Pin E	Supply (GND)	0V
Pin F	Supply (+)	12 ... 28VDC
Pin G	Signal speed (option)	5V TTL
Pin H	NC	-
Pin J	RS422 (option) ¹	RS422 (-)
Pin K	NC	-
Pin L	RS422 (option) ¹	RS422 (+)
Pin M	Shield	-

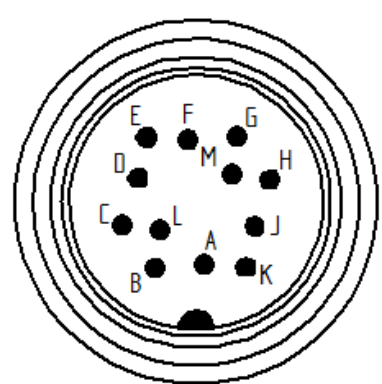

¹ Output signal via the RS422 interface, in addition to the analog output signal

Technical Data acc. to VDI/VDE/DKD 2639

Torque Measuring Flange DR-2800

Rated torque M_{nom}	N·m	50 ... 10000
Accuracy class	% M_{nom}	0.1
Relative repeatability error in unchanged mounting position b'	% M_{nom}	±0.02
Rated range of supply voltage	VDC	12 ... 28
Current consumption	mA	≤50
Output signal	V	±5
Electrical connection		12-pin series 581 ²
Reference temperature T_{ref}	°C	23
Rated temperature range	°C	5 ... 45
Operating temperature range	°C	0 ... 60
Storage temperature range	°C	-10 ... 70
Temperature effect on zero signal TK_0	% $M_{nom}/10\text{ K}$	±0.2
Temperature effect on characteristic value TK_C	% $M_{nom}/10\text{ K}$	±0.1
Maximum operating torque M_G (static)	% M_{nom}	130
Torque limit M_{max} (static)	% M_{nom}	200
Breaking torque M_B (static)	% M_{nom}	>300
Permissible oscillation stress when subjected to torque M_{df}	% M_{nom}	70 (peak-to-peak)
Balancing grade (DIN ISO 1940)	Q	6.3
Level of protection		IP54

Article-No.	Rated Torque [N·m]	Limit Speed [min ⁻¹]	Spring Rate [N·m/rad]	Mass Moment of Inertia [kg·m ²] ³		Axial Force Limit [N]	Lateral Force Limit [N]
				Drive Side	Test Side		
113605	50	15000	8.3E+04	5.8E-03	1.1E-03	650	190
113607	100	15000	1.4E+05	5.8E-03	1.1E-03	1100	330
113608	200	15000	3.2E+05	9.2E-03	1.8E-03	1600	550
113609	500	12000	1.1E+06	1.3E-02	4.0E-03	2000	1200
113610	1000	12000	3.5E+06	1.3E-02	4.1E-03	4000	2700
114349	2000	10000	6.7E+06	3.1E-02	1.3E-02	5400	3300
114350	5000	8000	14.3E+06	7.8E-02	3.0E-02	5700	5200
117720	10000	8000	14.3E+06	7.8E-02	3.0E-02	5700	5200

Options

Article-No.	Description	
103562	Output signal	±10V
118080	Output signal	10 kHz ±5 kHz (RS422)
118110	Output signal	60 kHz ±30 kHz (RS422)
113627	Speed measurement, 1 x 30 impulses	5V TTL

² Female cable connector in scope of delivery at first delivery

³ Without option speed measurement

Calibrations

Article-No.	Description	
400676	Linearity diagram in accordance to factory standard	25 % steps
400664	Linearity diagram in accordance to factory standard	10 % steps
400961	Proprietary calibration acc. to VDI/VDE 2646	3 steps
400700	Proprietary calibration acc. to VDI/VDE 2646	5 steps
400688	Proprietary calibration acc. to VDI/VDE 2646	8 steps
	DAkKS-Calibration/Standard on request	

Accessories

Electrical Connection

Article-No.	Description
41382	Female cable connector 12-pin series 581
45598	Female angled connector 12-pin series 682
10270	Connection cable, 3 m, with 12-pin female cable connector series 581 and free strands
10345	Connection cable angled, 3 m, with 12-pin female angled connector series 682 and free strands

Amplifiers

Examples of suitable amplifiers for the torque measuring flange DR-2800:



Further suitable amplifiers you can find on our homepage under <https://www.lorenz-messtechnik.de/english/products/>.