

**CURTISS -
WRIGHT**



JC150 SINGLE AXIS JOYSTICK CONTROLLER

Innovation In Motion

INNOVATION IN MOTION

The JC150 single-axis joystick controller is designed for demanding operator control applications in off-highway vehicles and other man-machine interfaces, where lever strength, signal reliability, and handle functionality are important. The joystick is supplied with a long life conductive plastic potentiometer track and directional/center off or end switches to provide signals for sensing lever direction and fault detection. The JC150's compact size, high lever strength and superb proportional control are ideal for applications which include operator controls on a wide range of off-highway vehicles, including cranes, loaders, excavators, access platforms, tractors and harvesters.

Handles and multifunction grips

The JC150 can be specified with a choice of handles and multifunction grips to increase the functionality of the operator controls. With a choice of push buttons, trigger grips, proportional and switched rockers in a variety of different configurations, users can match their handle selection to suit their unique application. A center or end locking handle is also available to provide a mechanical safety lock – eliminating unwanted movement of the lever.



Innovative design

With a choice of potentiometer tracks that provide the analog signals proportional to lever movement, the JC150 can be configured to provide a range of output signals, directional/center or end switching functions, spring to center or friction hold lever movement and seven different handle styles. The JC150's rectangular profile below the panel allows a number of joysticks to be mounted side by side. All electrical signals terminate in a single AMP '040' multi-lock connector on the base, reducing installation time.

Features

- Potentiometric sensing
- Spring to center or friction hold single axis control
- High strength lever with superb proportional control
 - Locking handle option
 - Sealed above the panel to IP65
 - Choice of outputs and switches
- Choice of handles/grips with or without switches
 - AMP '040' series multi-lock connector

Benefits

- Long life and maintenance-free operation
- Suited to a range of operator control functions
- Rugged and smooth lever movement
- Eliminates unwanted lever movement
- Operation in demanding environments
- Enables user configuration for system safety
- Additional operator control functions
- Simple, error free installation



Quality Assurance
Penny+Giles are accredited to BS EN ISO9001:2008
Quality is at the heart of all our systems ensuring the reliability of our products from initial design to final despatch.

Certificate No. LRO 0924881



EMC Directive 2004/108/EC
The products detailed in this document are supplied as components for installation into an electrical apparatus or system. They are outside the scope of the EEC directive and will not be CE marked.

JC150 SINGLE-AXIS JOYSTICK CONTROLLER

Total reliability

The JC150 includes lever mechanics designed to give smooth proportional control, and has been designed to withstand a load on the handle up to 300N, measured 135mm above the panel. Conductive plastic potentiometer tracks featuring multi-fingered precious metal wipers give low electrical noise and a working life greater than 2 million operations with zero maintenance during this period.



Safety

Designed to interface with an electronic controller, the long-life potentiometer track generates analog outputs with switched reference signals that are proportional to the distance and direction over which the lever is moved. The analog output can be configured to provide signals for fault detection circuits, and a center tap provides an accurate voltage reference for the center position or a zero point for a bipolar supply voltage. The electrically independent directional switch operates with separate contacts each side of the joystick center position, with an option for an end of travel switch. Penny & Giles recommend that the design of the separate machine controller should execute a fault routine if it detects a signal that is outside the specification

The key advantages of this technology are its linear output and the versatility it derives from its simplicity; it consists of a carbon-based potentiometer track with no complex circuitry or electronics, so it is not susceptible to electromagnetic interference or magnetic fields. However, as a contacting device it does have a long, but finite life and due consideration should be given to applications subject to high intensity use or where high levels of dither or vibration may be encountered.



Custom design

Penny + Giles offer an extensive range of fingertip and hand operated joysticks in standard modular configurations, designed to meet the majority of individual customer needs, but we can customise our designs for OEMs who require something more specialised to their application. Please talk to our technical sales team about your requirements.

Cell manufactured

The modular design of the JC150 joystick is designed to provide the user with a wide choice of options, but allows rapid build and despatch. Contact your nearest sales office for the latest information on availability.



JC150 JOYSTICK CONTROLLER

PERFORMANCE MECHANICAL

Lever action		Self centering (standard) or friction lock (FL option)
Lever breakout force*	N	4.9 to 10.7 (standard)
	N	13 to 17 to overcome detent - FL option
Lever operating force**	N	16.8 to 21.5 (Standard - full lever deflection)
	N	8 to 12 when out of detent - FL option
Maximum allowable force**	N	300
Lever operating angle	°	±34
Expected life (operations)		Greater than 2 million (0.5 million for Friction Lock (FL) action or handle options CL and EL)
Weight	g	560 without handle fitted

* Measured at 75mm above upper flange face (80mm for FL option) ** Measured at 135mm above upper flange face

ENVIRONMENTAL

Operating temperature	°C	-20 to +70
Storage temperature	°C	-40 to +85
Environmental protection above the flange		IP65 IEC 60529

ELECTRICAL Analog Track

Resolution		Virtually infinite
Track resistance (±20%)	kΩ	1.6, 2, 2.9, 5, 10
Track electrical angle	°	±32
Output voltage range	%	0-100, 10-90, 25-75 of input voltage
Center tap voltage	%	48 - 52 of applied voltage
Center tap angle	°	±2.5
Supply voltage - maximum	Vdc	35
Wiper circuit impedance	MΩ	1 minimum recommended***
Power dissipation @ 25°C	W	0.25 (no load)
Insulation resistance		Greater than 50MΩ at 500Vdc

***The long life resistive elements require a high impedance load in the wiper circuit to minimise the current flowing through the wiper for optimum life conditions

Switch- Directional or Center off

Switch operating angle ° Standard 5 or 7.5 either side of center

End Switch

Switch operating angle ° Optional 28.5 either side of center

Supply voltage - maximum Vdc 35

Load current - maximum mA 10 (resistive)

ANALOG TRACK & SWITCH DIAGRAM

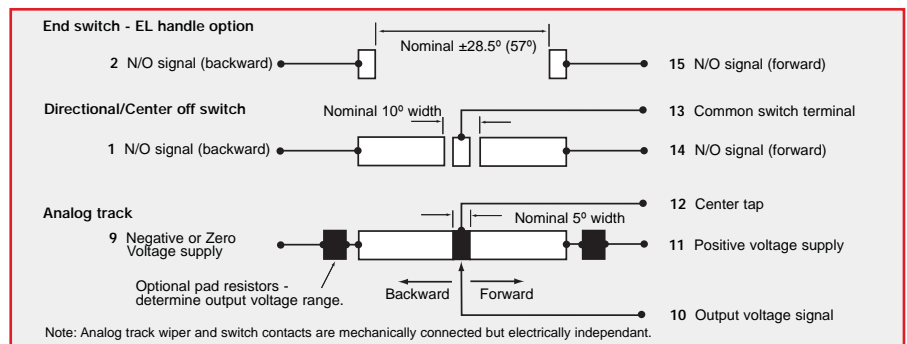

JC150 JOYSTICK CONTROLLER

DIMENSIONS

Note: drawings not to scale

INSTALLATION

The joystick is designed to be fitted from below the mounting panel, through a 42 - 44mm diameter hole. The effectiveness of the joystick flange sealing is dependent on the panel mounting surface being sufficiently rigid to compress the sealing gaiter. The surface finish of the mounting panel is critical to achieving an adequate seal and rough surface finishes, paint chips, deep scratches, etc. should be avoided.

Recommended panel thickness
3.5 to 6mm

Recommended screw torque
M5 fixing screws can be driven to a maximum torque of 3.5Nm when clamped against a 3.5mm thick panel.

The mounting hole depth is 13mm.

The joystick mounting flange should be connected to the vehicle chassis or reference plane (normally zero volts).

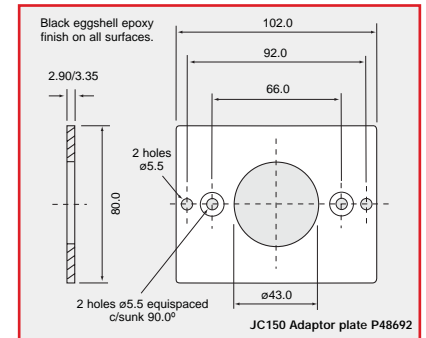
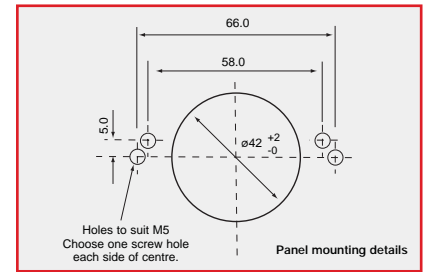
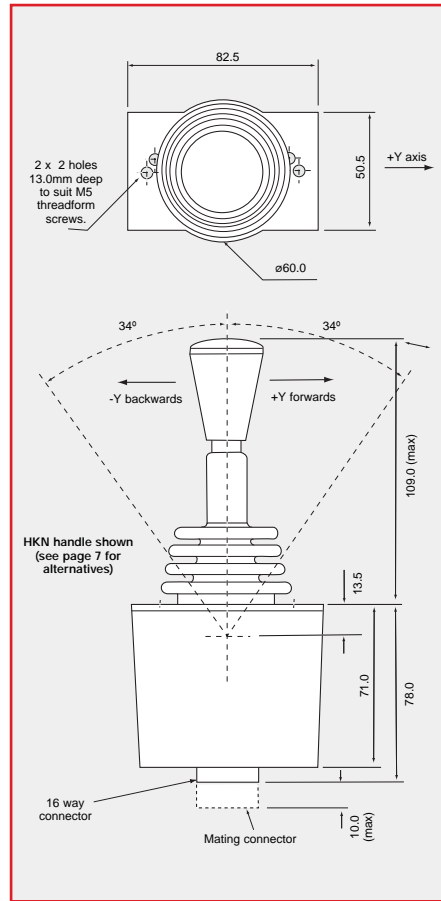

MOUNTING PLATE DETAILS

When the JC150 is selected with the 'A' range handle option, an adaptor plate (P48692) is required to mount the joystick assembly from the top of the panel.

ELECTRICAL CONNECTIONS

Mating 16 way connector and pins

Mating 16 way harness

All potentiometer track and directional/center/end switch connections terminate in a single 16-way AMP '040' series multi-lock connector in the joystick base.

SA47931 (AMP 040 16 Way Connector 174046-2; Pins 175062-1 suitable for 20-24 AWG wire size)

P49780 (Connector, Pins and 380mm long cable with 16/0.2mm wires - 20 AWG)

Description	Connector Pin Number
Positive voltage supply	11
Center tap	12
Negative or zero voltage supply	9
Output voltage signal	10
Directional switch track N/O signal (lever forward +Y)	14
Directional switch track N/O signal (lever backward -Y)	1
End switch track N/O signal (lever fully forward +Y)	15 (EL handle option)
End switch track N/O signal (lever fully backward -Y)	2 (EL handle option)
Common terminal for directional switches	13
Common terminal for handle switches	16
	3
	4
	5
	6
	7
	8

Please refer to handle data sheets for detailed connections on chosen handle

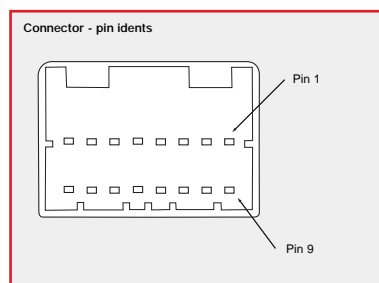

JC150

JOYSTICK CONTROLLER HOW TO SPECIFY

PERFORMANCE OPTIONS	FEATURE	CODE
AXES	Single	Y
TRACKS	Analog potentiometer - 5k, 0-100%, $\pm 7.5^\circ$ directional switch Analog potentiometer - 10k, 0-100%, $\pm 7.5^\circ$ directional switch Analog potentiometer - 1.6k, 0-100%, $\pm 7.5^\circ$ directional switch Analog potentiometer - 2.9k, 25-75%, $\pm 5^\circ$ directional switch Analog potentiometer - 2k, 10-90%, $\pm 5^\circ$ directional switch Analog potentiometer - 2k, 10-90%, $\pm 7.5^\circ$ directional switch Analog potentiometer - 2.9k, 25-75%, $\pm 7.5^\circ$ directional switch	E L N Q R S T
LEVER SPRING FORCE	Medium duty spring to center, 7.8N breakout, 19.1N full deflection (nominal) No spring option selected - go to Special Options for Friction Lock feature	M /
HANDLE/GRIP STYLE See pages 7-15	Standard knob, no functions Center lock handle End lock handle Trigger grip with optional button or rocker switching Ergonomic grip with multiple buttons and proportional rockers Trigger grip with optional 4-way rocker switching	HKN CL EL MG A W
INTERFACE	Standard interface board (no electronics) Standard interface board, with adaptor plate - use when A handle selected	STN STA
SPECIAL OPTIONS	Friction lock with no detents along whole axis Friction lock with detent at center position only Friction lock with detent at center and full travel position Friction lock with detent at full travel position only Friction lock with detent at center and 25° either side of center Friction lock with detent at 25° either side of center	FLD0 FLD1 FLD2 FLD3 FLD4 FLD5

EXAMPLE ORDER CODE

JC150-Y-R-M-HKN-STN

JC150 JOYSTICK CONTROLLER HANDLE OPTIONS

HKN

The HKN handle is the simplest option available for the JC150. This handle does not include any additional functionality, but is designed to allow the JC150 joystick to be controlled by the operator gripping the handle, palm downwards.



CL/EL

Developed to improve the integrity of your control system, the Center Lock (CL) and End Lock (EL) handles provide a mechanical safety lock – eliminating unwanted movement of the lever. They mechanically hold the shaft of the JC150 in its safe central position or at either end of the JC150's range of travel. Lifting the collar under the base of the handle unlocks the shaft.



MG RANGE

This option is designed to provide a simple approach to a 'Person Present' handle. The 'MG' range can be supplied with or without an operator's hand rest and can be configured with a combination of momentary action button or rocker switch in the top of the handle, with a trigger switch at the front of the hand grip. The handle profile ensures the operator's fingers are permanently close to the buttons, minimising operator fatigue and maximising functional control. This handle can also be purchased separately, for fitting to customer levers or assemblies. Ask our sales team for more details on this option.



A RANGE

This option is designed to meet the demands for more complex control systems in off-highway applications. The 'A' range of ergonomic multifunction hand grips can be fitted with a combination of analog outputs, push button and 'Person Present' switches. The handle can be supplied with two independent analog outputs generated by proportional rockers which, in turn, provide auxiliary directional switching in addition to the potentiometric output. When coupled with the JC150 joystick, this unit can provide a three-axis control device.

This handle can also be purchased separately, for fitting to customer levers or assemblies. Ask our sales team for more details on this option.



W RANGE

This option provides an alternative approach to a 'Person Present' handle whilst offering the flexibility of multiple switches in the top of the handle. The 'W' range can be supplied with (WT) or without (WN) the 'Person Present' trigger switch as well as up to four switches in the handle top. These can be specified to be in any of the four 'on axis' positions.



HKN HANDLE OPTION

DIMENSIONS

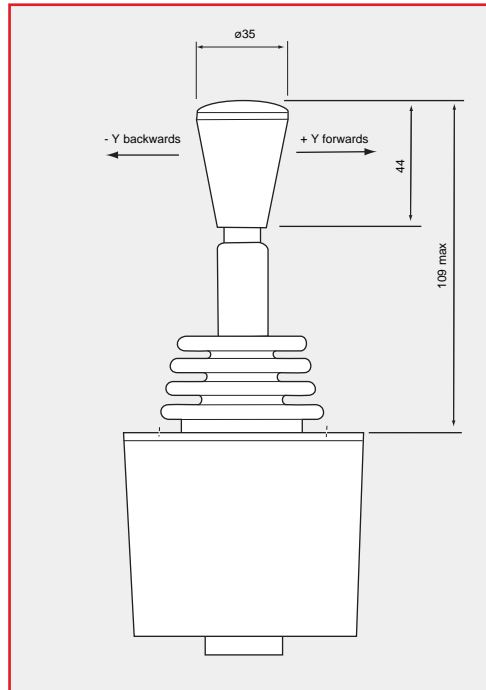

SPECIFICATION

Handle material
Colour
Handle retention force

Gloss finish duroplast
Black
60N min

CL/EL HANDLE OPTION

DIMENSIONS

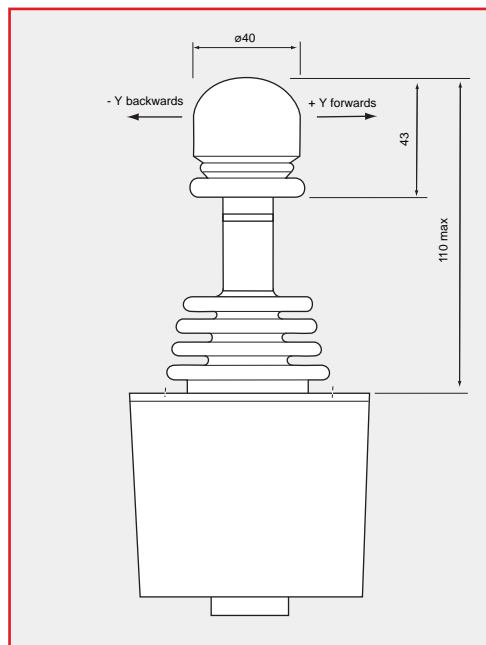

SPECIFICATION

Handle material
Colour

Neoprene rubber
Black

HB HANDLE OPTIONS

NO LONGER AVAILABLE

PAGE LEFT INTENTIONALLY BLANK

MG HANDLE OPTIONS

DIMENSIONS

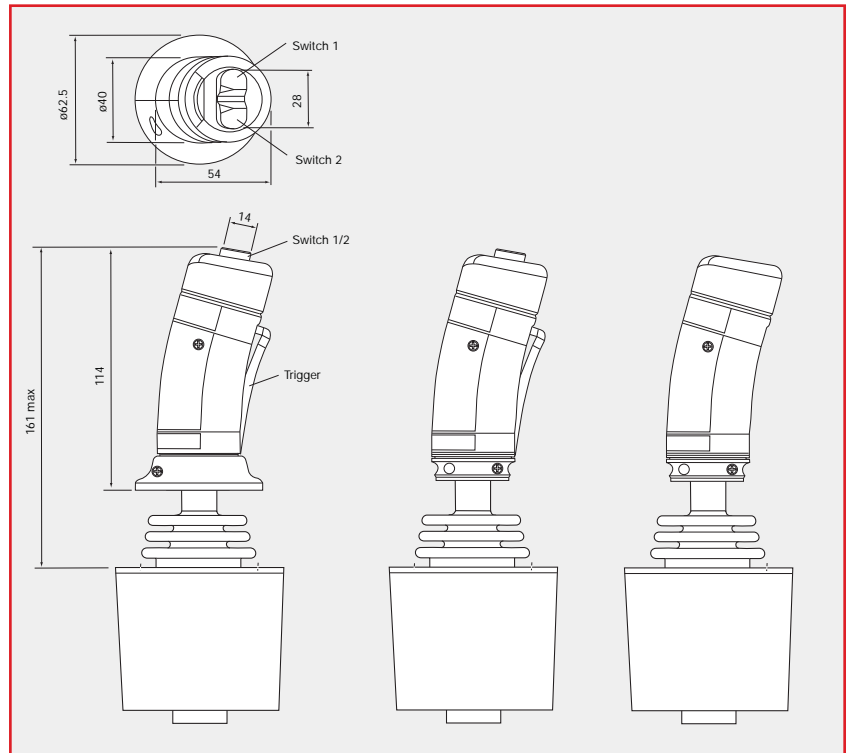

SPECIFICATION

Maximum height above flange	mm	161
Maximum grip diameter	mm	40
Environmental sealing (IEC 60529)		IP67 (IP66 with trigger switch)
Number of switches		0 to 3
Action		Momentary Button (1), Rocker (1+2) or Trigger
Switch operating force		
Trigger	N	5
Switch 1 or 2	N	7
Maximum current @ 30Vdc	mA	100
Expected life (operations)		1 million
Operating temperature	°C	-25 to +75
Storage temperature	°C	-30 to +80

HANDLE CODE

HANDLE CODE	Top switch position	Trigger switch	Hand rest
MG00	None	No	No
MG01	1	No	No
MG02	1 & 2	No	No
MG03	1 & 2	Yes	No
MG04	1 & 2	Yes	Yes
MG05	1	Yes	Yes
MG06	1 & 2	No	Yes
MG07	1	No	Yes
MG08	1	Yes	No
MG09	None	Yes	Yes
MG10	None	No	Yes
MG11	None	Yes	No

See electrical connections for wire color codes.

ELECTRICAL CONNECTIONS

	Pin number	Wire color
Common terminal (for top switches)	16	Black
Switch 1	6	Blue
Switch 2	3	Green
Trigger switch	4	Blue/Orange
Trigger switch	5	Yellow

A RANGE HANDLE OPTIONS

SPECIFICATION

Maximum height above flange mm	166
Maximum grip diameter mm	61
Environmental sealing (IEC 60529)	IP65
Number of switches	1 to 6 in the top plate
Action	Momentary button
Switch operating force	N 3
Maximum current @ 50Vdc	mA 200
Expected life (operations)	1 million
Weight	g 170 - A2LD option
Operating temperature	°C -40 to +70
Storage temperature	°C -40 to +80

ROCKER

Rocker profile		Standard (S) or V profile (V)
Breakout force	N 5	at the end of the rocker
Operating force	N 15	at the end of the rocker
Mechanical movement	° ±10 (±1°)	
Electrical movement	° ±9 (±1°)	
Expected life (operations)		5 million
Load current (maximum)	mA 200	(see note on page 4)
Power dissipation @ 25°C	W 0.25	
Track resistance		Will match JC150 resistance [†]
Output voltage		Will match JC150 output [†]
Center tap angle	° ±1.5	
Directional or center off switch		Standard
Switch gap	° 2.5	either side of center
Switch supply voltage	Vdc 35	

[†] Unless requested otherwise.

FUNCTIONALITY

SWITCHES

ROCKERS

	1	2	3	4	5	6	TOP	Person Present	LEFT	RIGHT	HORIZONTAL
SWITCH 1	✓	✓	✓	✓	✓	✓	✓	✓	✓		
SWITCH 2	✓		✓	✓	✓	✓	✓	✓	✓		✓
SWITCH 3	✓	✓		✓	✓	✓	✓	✓		✓	✓
SWITCH 4	✓	✓	✓		✓	✓	✓	✓		✓	
SWITCH 5	✓	✓	✓	✓		✓	✓	✓			
SWITCH 6	✓	✓	✓	✓	✓		✓	✓			
TOP SWITCH	✓	✓	✓	✓	✓	✓		✓	✓	✓	
PERSON PRESENT	✓	✓	✓	✓	✓	✓	✓		✓	✓	✓
LEFT ROCKER	✓	✓					✓	✓			
RIGHT ROCKER			✓	✓			✓	✓			
HORIZONTAL		✓	✓					✓			

SWITCH AND ROCKER OPTIONS

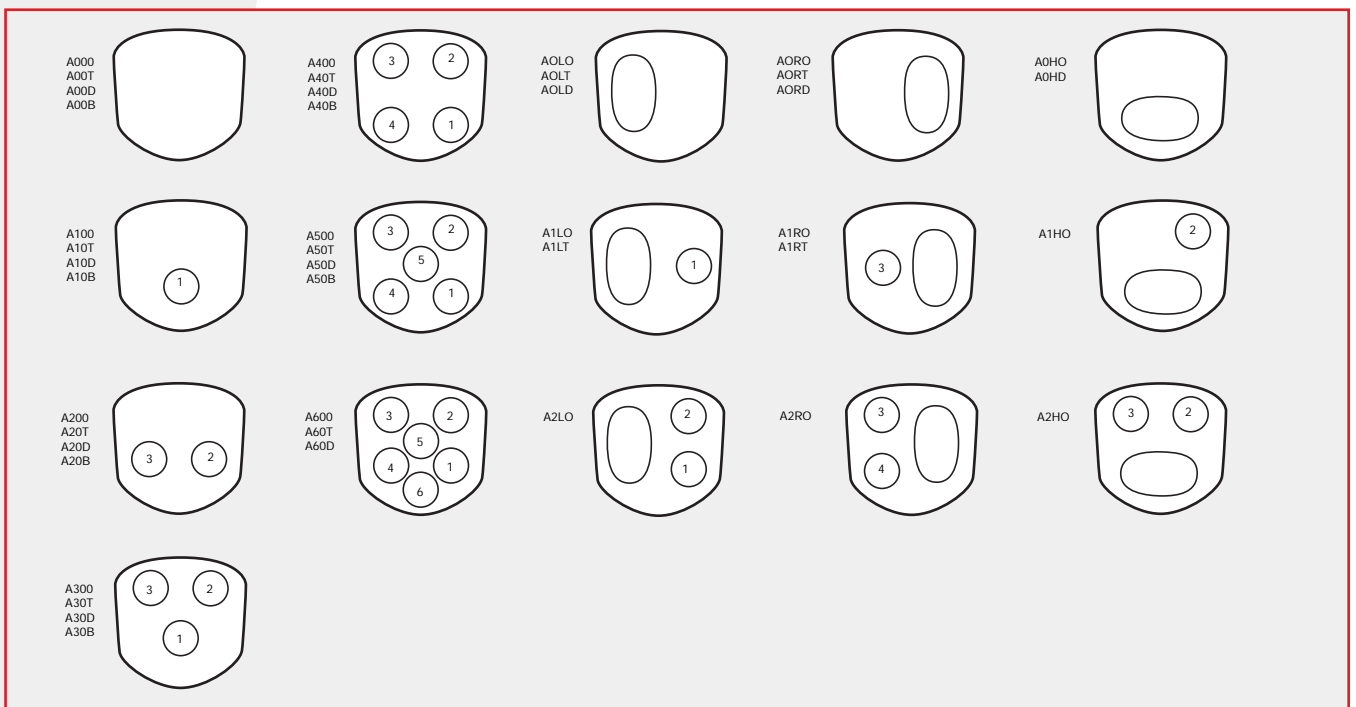

DIMENSIONS

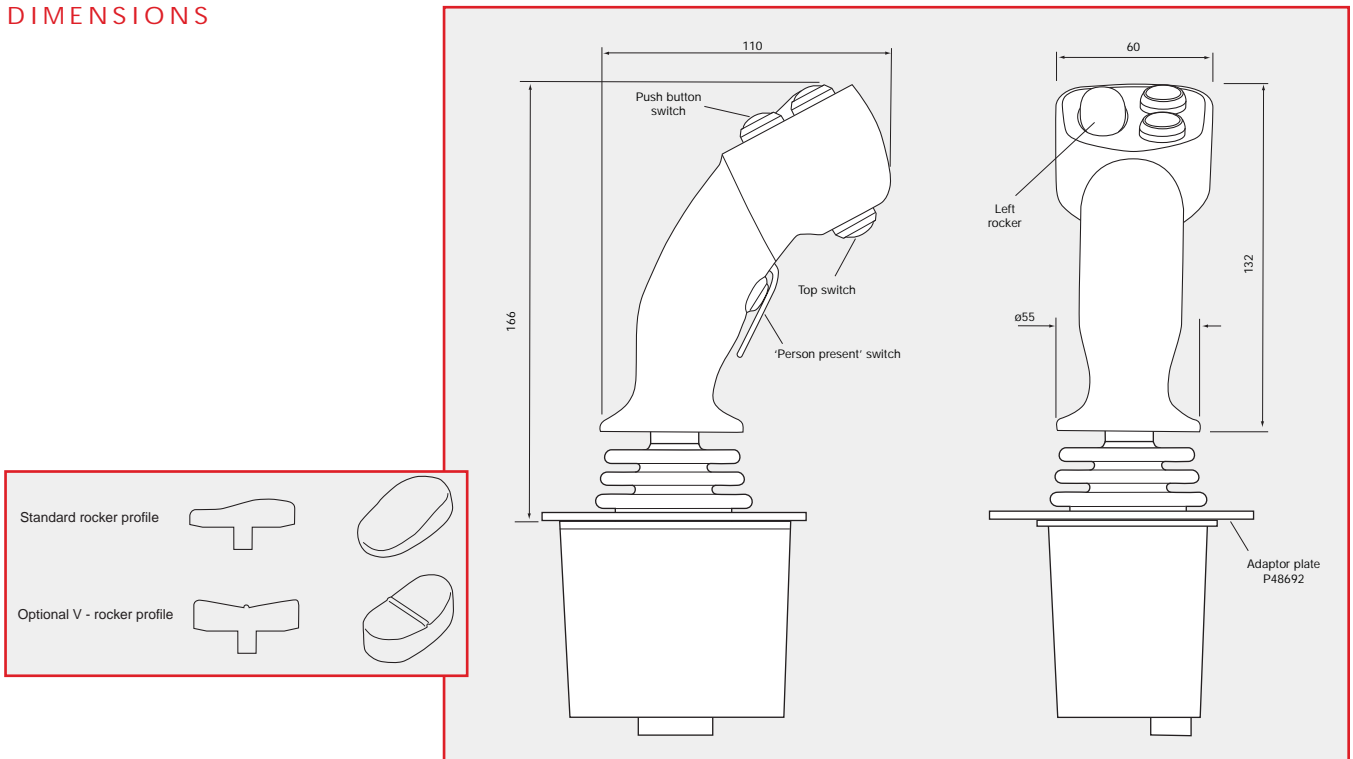

ELECTRICAL CONNECTIONS

Pin	Wire color	Pin	Wire color
Common terminal (for all switches)	16 Black	Rocker center tap	8 Yellow/Red
Switch 1	6 Blue	Rocker zero or negative supply (L, R or H)	15 Pink/Grey
Switch 2	5 Yellow	Rocker output signal (L or H)	7 Pink
Switch 3	4 Blue/White	Rocker output signal (R)	7 White
Switch 4	3 White/Green	Rocker switch common	16 Black
Switch 5	7 Red	Rocker switch (L forward)	4 Blue/Orange
Switch 6	8 Violet	Rocker switch (L backward)	3 Green
Top switch	† Pink with marker	Rocker switch (R forward)	5 Yellow
Person present switch	† Red/Green	Rocker switch (R backward)	6 Blue
Person present switch	† Black/White	Rocker switch (H left)	6 Blue/Orange
Rocker positive supply (L, R or H)	2 White/Red	Rocker switch (H right)	3 Green

† Depends on other options selected

ORDERING CODES

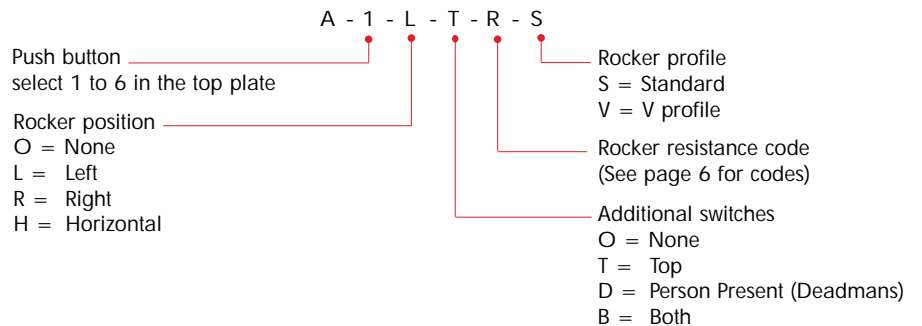

Note: When ordering a handle fitted with a rocker, two profiles can be supplied (S = standard profile; V = v profile) please specify style when ordering.

WT/WN HANDLE OPTIONS

DIMENSIONS

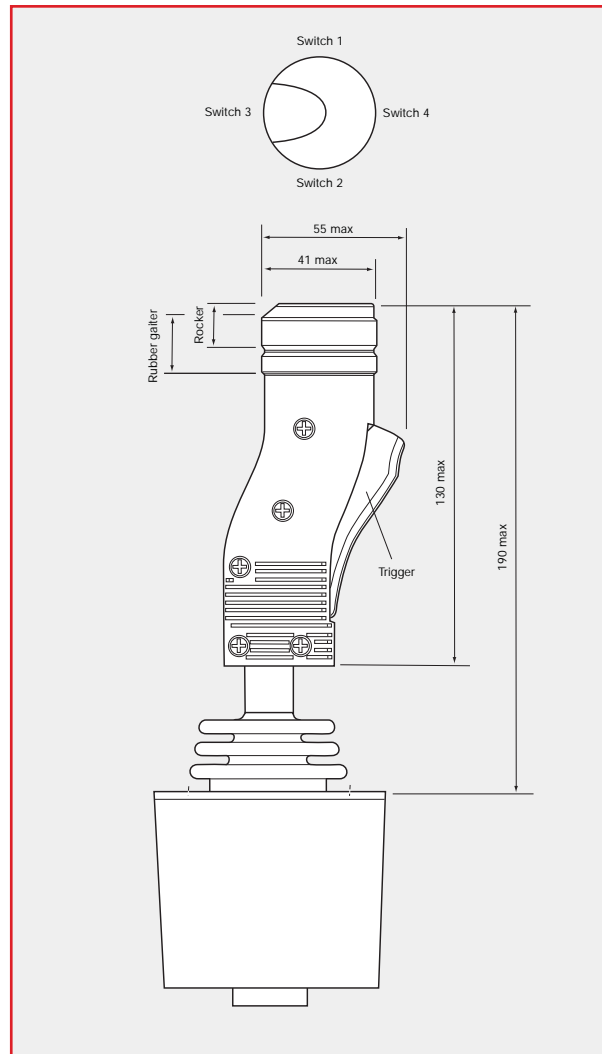

SPECIFICATION

Maximum height above flange	mm	190
Maximum grip diameter	mm	40.5
Environmental sealing (IEC 60529)		IP66
Number of switches		0 to 5
Action		Momentary Rocker or Trigger
Switch operating force		
Switch 1, 2, 3 & 4	N	5 at 11mm radius (Rocker switches)
Trigger	N	3 at center line of Trigger switch
Maximum current @ 30Vdc	mA	100 (Rocker switches)
Maximum current @ 28Vdc	A	5 resistive (Trigger switch – two wires connected)
Expected life (operations)		1 million at full power (Rocker switches)
		500,000 @ 1A resistive (Trigger switch)
Operating temperature	°C	-40 to +70
Storage temperature	°C	-40 to +80

HANDLE CODE

Trigger	No Trigger	Rocker switches in position			
WT00	WN00	No rockers			
WT01	WN01	1	-	-	-
WT02	WN02	-	2	-	-
WT03	WN03	-	-	3	-
WT04	WN04	-	-	-	4
WT05	WN05	1	2	-	-
WT06	WN06	1	-	3	-
WT07	WN07	1	-	-	4
WT08	WN08	-	2	3	-
WT09	WN09	-	2	-	4
WT10	WN10	-	-	3	4
WT11	WN11	1	2	3	-
WT12	WN12	1	2	-	4
WT13	WN13	1	-	3	4
WT14	WN14	-	2	3	4
WT15	WN15	1	2	3	4

Note: Two switches can be operated by deflecting the handle top at 45°

ELECTRICAL CONNECTIONS

	Pin number	Wire color
Common terminal (for Rocker switches)	16	Black
Switch position 1	6	Blue
Switch position 2	3	Green
Switch position 3	8	Yellow/Red
Switch position 4	7	Pink
Trigger switch	4	Blue/Orange (Two wires)
Trigger switch	5	Yellow (Two wires)

CURTISS - WRIGHT

www.cw-industrialgroup.com

Penny & Giles
Position sensors, joysticks and
solenoids for commercial and
industrial applications.

36 Nine Mile Point Industrial Estate
Cwmfelinfach
Gwent NP11 7HZ
United Kingdom
+44.1495.202000
cwig.uk@curtisswright.com

10 Airspeed Road
Christchurch
Dorset BH23 4HD
United Kingdom
+44.1425.271444
cwig.uk@curtisswright.com

210 Ranger Street
Brea, CA 92821
USA
+1.714.982.1862
cwig.us@curtisswright.com

Schleissheimer Str. 91A
85748 Garching
Germany
+49.89.5404.100.0
cwig.de@curtisswright.com

Rm 1007, No.8 Dong An Rd
No.8 Dong An Rd
Shanghai, 200032
People's Republic of China
+86.21.3331.0670
cwig.cn@curtisswright.com

The information contained in this brochure on product applications should be used by customers for guidance only. Penny & Giles Controls Ltd makes no warranty or representation in respect of product fitness or suitability for any particular design application, environment, or otherwise, except as may subsequently be agreed in a contract for the sale and purchase of products. Customer's should therefore satisfy themselves of the actual performance requirements and subsequently the products suitability for any particular design application and the environment in which the product is to be used.

Continual research and development may require change to products and specification without prior notification. All trademarks acknowledged.

© Penny & Giles Controls Ltd 2012

Innovation In Motion