

The **Penny+Giles ICT100 Contactless In-Cylinder Linear Transducer** has been specifically designed for mobile and static hydro-pneumatic actuators.

Designed primarily for the off-highway markets, the ICT100 linear transducer provides reliable, fit-and-forget position sensing of the cylinder rod in actuators with strokes up to 2000mm, with a body diameter of only 10.1mm.

It is a robust, non-contact transducer suitable for the harsh conditions of lifting and steering position applications and hydro-pneumatic active suspension systems. It works on an inductive coil principle, with virtually infinite resolution and is capable of withstanding temperatures down to -55°C and up to +200°C, with working pressures to 670Bar (10,000psi).



ICT100

IN-CYLINDER LINEAR TRANSDUCER

www.pennyandgiles.com

Penny & Giles Controls Ltd
15 Airfield Road
Christchurch
Dorset BH23 3TG
United Kingdom
+44 (0) 1202 409409
+44 (0) 1202 409475 Fax
sales@pennyandgiles.com

Penny & Giles USA
665 North Baldwin Park Boulevard
City of Industry
CA 91746
USA
+1 626 480 2150
+1 626 369 6318 Fax
us.sales@pennyandgiles.com

www.penny-giles.de

Penny & Giles GmbH
Straussenlettenstr. 7b
85053
Ingolstadt
Germany
+49 (0) 841 885567-0
+49 (0) 841 885567-67 Fax
info@penny-giles.de

METRIC
IF IN DOUBT ASK

SPECIFICATION

ELECTRICAL STROKE LENGTH 25mm TO 200mm (IN 5mm INCREMENTS)
 210mm TO 1100mm (IN 10mm INCREMENTS)
 1120mm TO 2000mm (IN 20mm INCREMENTS)
 TEMPERATURE RANGE (OPERATING) SEE ORDERING CODE
 TEMPERATURE RANGE (STORAGE) -55°C TO +200°C
 TEMPERATURE PERFORMANCE <± 100ppm OF ELECTRICAL STROKE/°C (+20°C TO +60°C)
 <± 200ppm OF ELECTRICAL STROKE/°C (-20°C TO +100°C)
 <± 300ppm OF ELECTRICAL STROKE/°C (-20°C TO +200°C)
 LEAST SQUARES LINEARITY SEE ORDERING CODE
 RESOLUTION INFINITE
 MAX. WORKING PRESSURE 670 BAR
 INSULATION RESISTANCE YELLOW/ BLUE TO CASE >50MΩ @50Vdc
 SCREEN TO CASE >50MΩ @50Vdc
 GREEN WIRE BONDING RESISTANCE < 1 + (0.08 x CABLE LENGTH IN METRES)Ω, e.g. 20M CABLE = 1 + (0.08 x 20) = 2.60 Ω

NOTES
 1. STROKE LENGTH SPECIFIED BY CUSTOMER WITHIN RANGE 25mm TO 2000mm.
 2. THESE SPECIFICATIONS APPLY ONLY WHEN THE ICT IS OPERATED IN CONJUNCTION WITH A Penny & Giles 'EICT' ELECTRONIC MODULE.
 3. ELECTRONIC MODULES ARE ORDERED SEPARATELY, SEE APPROPRIATE Penny & Giles DATA SHEET(S)

PROGRAMMING MODULE
 EACH TRANSDUCER IS SUPPLIED WITH A SENSOR LENGTH MODULE CALIBRATED TO MATCH THE ELECTRICAL STROKE LENGTH. THE MODULE IS PLUGGED INTO THE REQUIRED 'EICT' ELECTRONIC MODULE VIA MATING CONNECTORS. IT IS IMPORTANT THE TRANSDUCER STROKE LENGTH AND THE SENSOR LENGTH MODULE STROKE LENGTH ARE MATCHED.
 E.G. SENSOR LENGTH MODULE SA203160/200
TRANSDUCER ICT100/EM/T/200/01

ORDERING CODE THREADED FLANGE

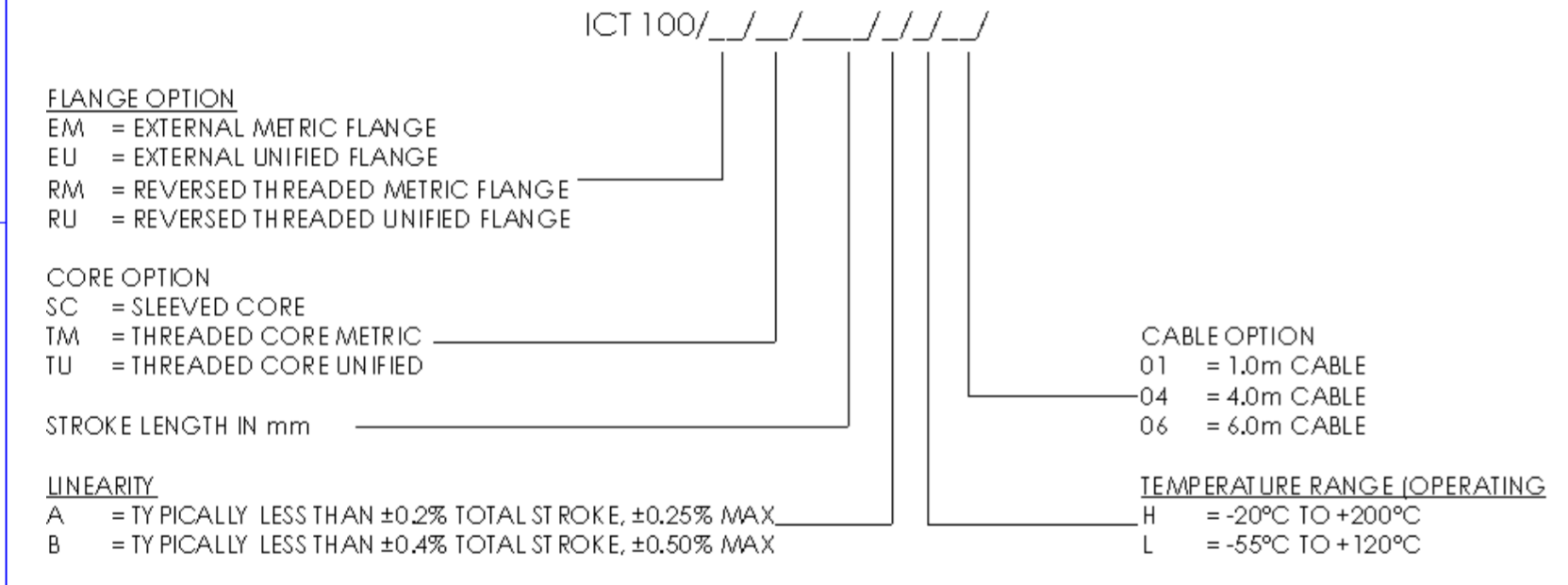

ORDERING CODE INTERNAL FLANGE

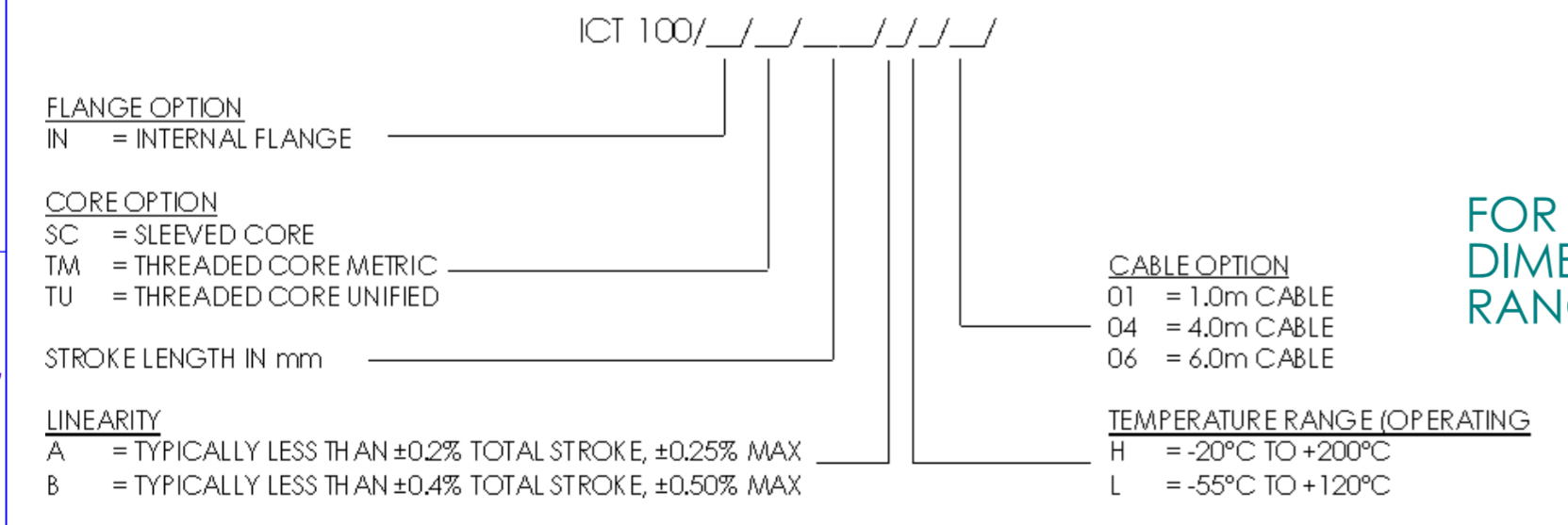

SCHEMATIC AND CONNECTION DETAILS

IDENTIFICATION	CASE	COIL	COIL	SCREEN
COLOUR	GREEN	YELLOW	BLUE	-----

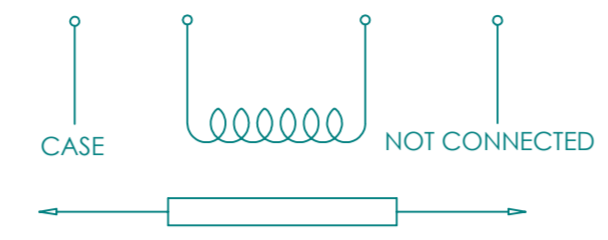

35.00mm OVER EXTENSION LIMIT, ALL CORES.

FOR SUGGESTED FITTING PROFILES AND DIMENSIONS, REFER TO AI202800 (H TEMP RANGE) OR AI207803 (L TEMP RANGE)

ISS	DATE	DRAWN	ECR No.	CHK	APP
5	10/03/11	S COLE	10306/31	M BENTLEY	M BENTLEY

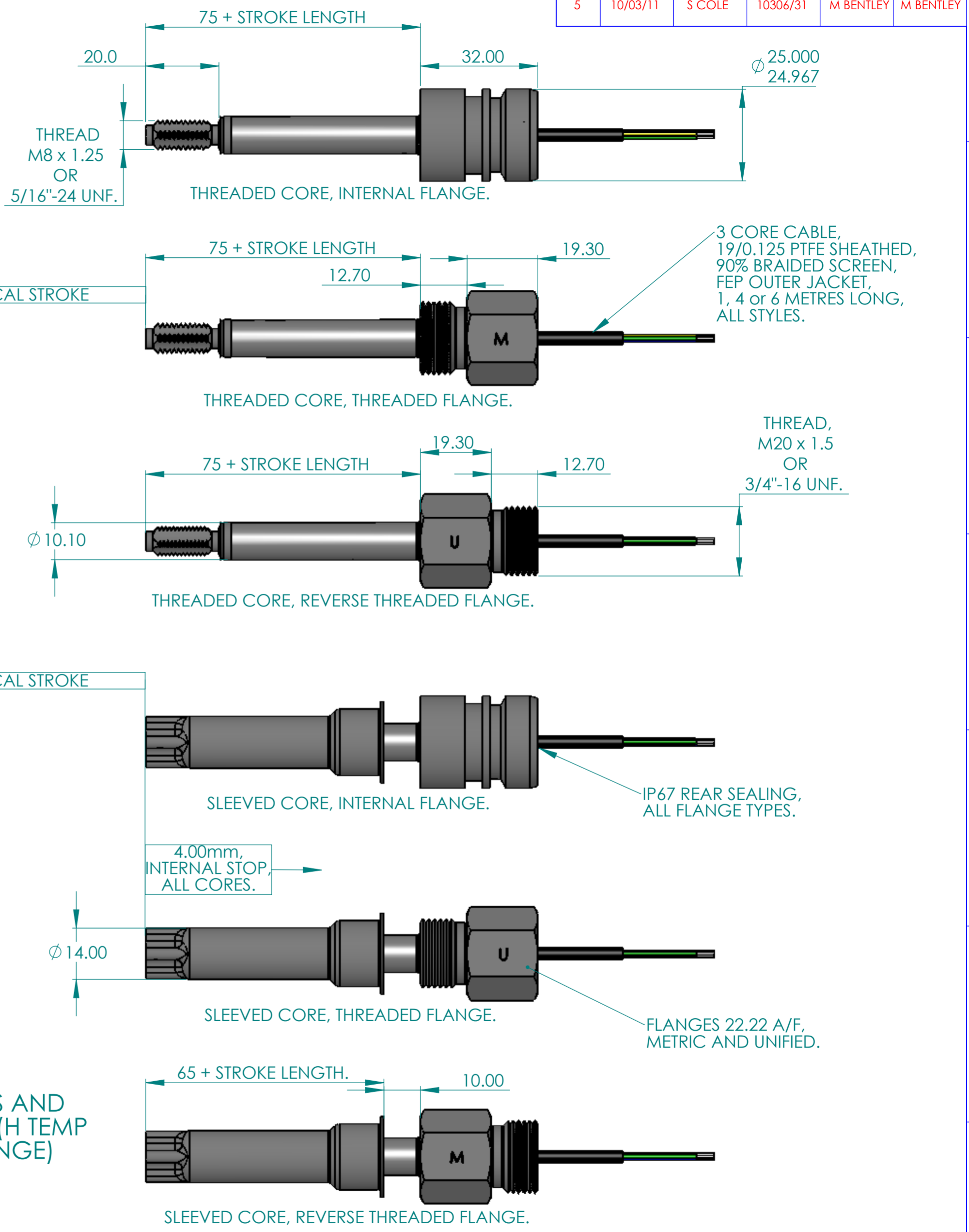

SCALE UNLESS STATED	IF CONTROL DIMENSIONS (Kc) ARE SPECIFIED THEY ARE TO BE SUBJECT TO 100% INSPECTION OR STATISTICAL PROCESS CONTROL.	D No. ICT100	MATERIAL ST/STEEL 303 + 316 NiFe ALLOY	TOLERANCES: IN-LINE WITH PENNY & GILES STANDARDS 55-301 SURFACE TEXTURE VALUES IN MICROMETRES (µm) TO BS1134:PT2. ALL MACHINED SURFACES TO BE 1.6 ALL SCREW THREADS TO BS3643 PT.2: EXTERNAL CLASS: 6g INTERNAL CLASS: 6H ANGULAR ± 1° LINEAR (MACHINING) 0.0mm +/- 0.5mm 0.0mm +/- 0.2mm 0.00mm +/- 0.1mm 0.000mm +/- 0.01mm BREAK EDGE 0.05 - 0.15mm FILLET RADS 0.1 - 0.3mm UNLESS OTHERWISE STATED	TITLE IN CYLINDER TRANSDUCER	PENNY + GILES	A2
THIRD ANGLE PROJECTION TO BS 8888	MASS (g)	VOL. (mm ³)	REF.	FINISH CLEAN	PART NUMBER: ICT100	SHT 1 OF 1 SHTS	SolidWorks

METRIC
IF IN DOUBT ASK

INSTALLATION KIT.

PRODUCTION CONTROL TO ENSURE A COPY OF THIS DRAWING IS INCLUDED WITH EACH INSTALLATION KIT.

BECAUSE OF THE MULTIPLICITY OF POTENTIAL APPLICATIONS THE INSTALLATION DETAILS SHOWN ARE SUGGESTIONS ONLY. THE USER SHOULD ENSURE THAT THE DESIGN, METHOD OF ASSEMBLY AND MATERIALS USED ARE SATISFACTORY FOR THE INSTALLATION.

ISS	DATE	DRAWN	ECR No.	CHK	APP
2A	10/03/11	S COLE	10306/31	M BENTLEY	M BENTLEY

ITEM No.	DESCRIPTION	P+G PART No.	QTY.
1	FULL NUT M8 x 1.25.	X63-072-380	1
2	FULL NUT 5/16"-24 UNF.	X63-111-002	1
3	WAVEY WASHER	X63-112-012	3
4	SHIM WASHER	P202677	1
5	CIRCLIP	X69-005-107	1
6	'O' RING (17 x 2)	X64-194-007	1
7	'O' RING (21 x 2.5)	X64-194-009	1
8	ANTI EXTRUSION RING	X64-074-003	1
9	MS CONICAL SET SCREW	X63-096-506	1
10	COPY OF A1202800	A1202800	1
11	LABEL (SUPPLIED LOOSE)	P200919	1
12	INSTALLATION KIT LABEL	P203193	1

ITEM 11 LABEL IS SUPPLIED FOR THE CUSTOMER TO RECORD ICT ORDERING CODE AND TO BE FITTED IN VISIBLE LOCATION ADJACENT TO SENSOR FOR RE-ORDERING REFERENCE.

INTERNAL FLANGE MACHINING DETAILS.

TO SEAL USE ITEMS 7 & 8

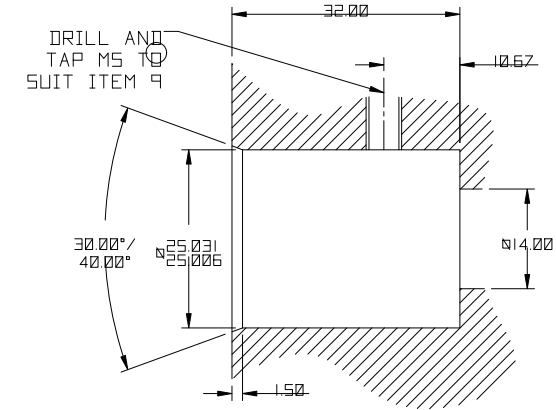

THREADED FLANGE MACHINING DETAILS.

TO SEAL USE ITEM 6

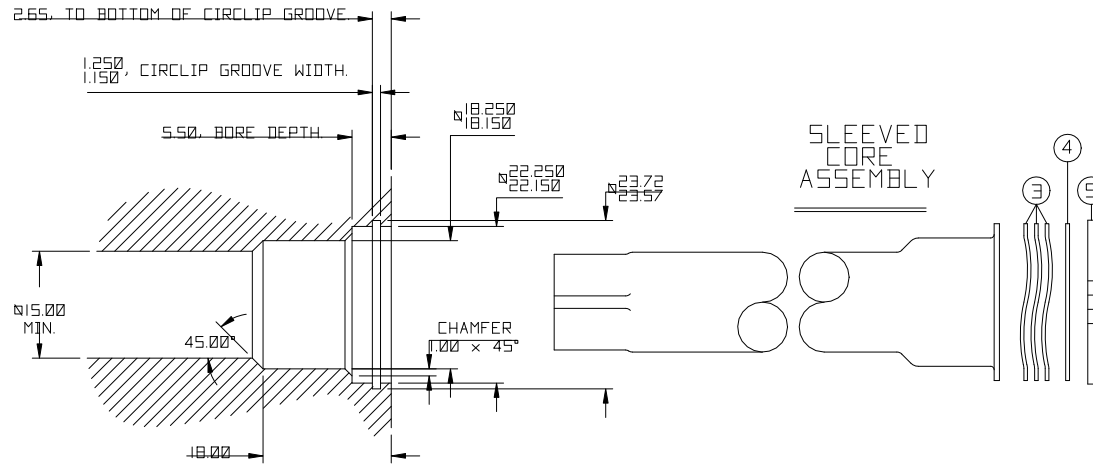
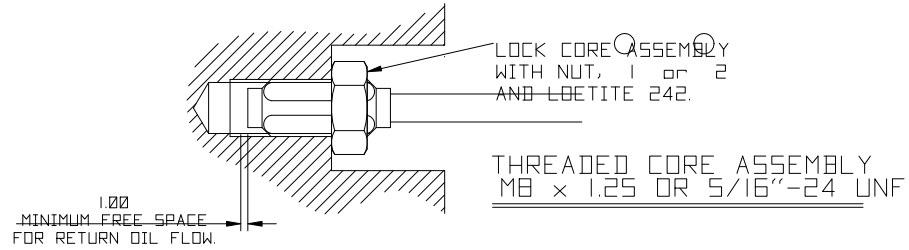
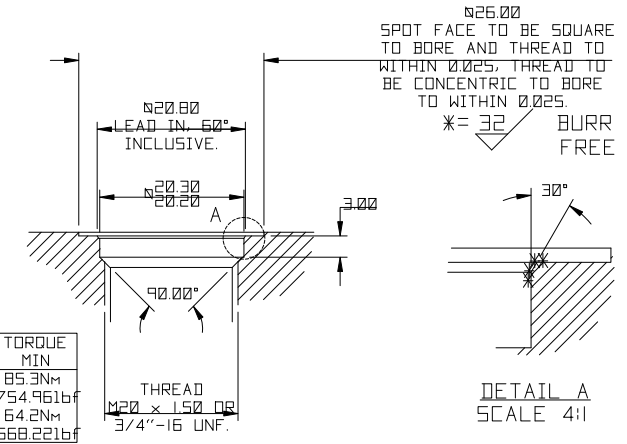

SCALE 1:1 UNLESS STATED	IF CONTROL DIMENSIONS (K) ARE SPECIFIED THEY ARE TO BE SUBJECT TO 100% INSPECTION OR STATISTICAL PROCESS CONTROL	D No ICT100 FIRST USED ON	MATERIAL -	TOLERANCES: IN-LINE WITH PENNY & GILES STANDARDS 33-501 SURFACE TEXTURE VALUES IN MICROMETRES (µ) TO BS1134PT2. ALL MACHINED SURFACES TO BE 1.6	TITLE SUGGESTED ICT100 INSTALLATION DETAILS AND INSTALLATION KIT 'H' TEMPERATURE RANGE	PENNY + GILES	A 3
THIRD ANGLE PROJECTION TO BS 8888	REF.	FINISH -	ANGULAR ± 1°	ALL SCREW THREADS TO BS3643 PT.2: EXTERNAL CLASS: 6h INTERNAL CLASS: 6H		PART NUMBER: A1202800	SHT 1 OF 1 SHTS
			LINEAR 0.05mm +/- 0.5mm 0.02mm +/- 0.2mm 0.002mm +/- 0.01mm	BREAK EDGE 0.05 - 0.15mm FILLET RADS 0.1 - 0.3mm			

METRIC
IF IN DOUBT ASK

INSTALLATION KIT.

PRODUCTION CONTROL TO ENSURE A COPY OF THIS DRAWING IS INCLUDED WITH EACH INSTALLATION KIT.

BECAUSE OF THE MULTIPLICITY OF POTENTIAL APPLICATIONS THE INSTALLATION DETAILS SHOWN ARE SUGGESTIONS ONLY. THE USER SHOULD ENSURE THAT THE DESIGN, METHOD OF ASSEMBLY AND MATERIALS USED ARE SATISFACTORY FOR THE INSTALLATION.

ISS	DATE	DRAWN	ECR No.	CHK	APP
1	10/03/11	S COLE	10306/31	M BENTLEY	M BENTLEY

ITEM No.	DESCRIPTION	P+G PART No.	QTY.
1	FULL NUT M8 x 1.25.	X63-072-380	1
2	FULL NUT 5/16"-24 UNF.	X63-111-002	1
3	WAVEY WASHER	X63-112-012	3
4	SHIM WASHER	P202677	1
5	CIRCLIP	X69-005-107	1
6	'O' RING (17 x 2)	X64-213-007	1
7	'O' RING (21 x 2.5)	X64-213-009	1
8	ANTI EXTRUSION RING	X64-074-003	1
9	MS CONICAL SET SCREW	X63-096-506	1
10	COPY OF A1207803	A1207803	1
11	LABEL (SUPPLIED LOOSE)	P200919	1
12	INSTALLATION KIT LABEL	P207804	1

ITEM 11 LABEL IS SUPPLIED FOR THE CUSTOMER TO RECORD ICT ORDERING CODE AND TO BE FITTED IN VISIBLE LOCATION ADJACENT TO SENSOR FOR RE-ORDERING REFERENCE.

INTERNAL FLANGE MACHINING DETAILS.

TO SEAL USE ITEMS 7 & 8

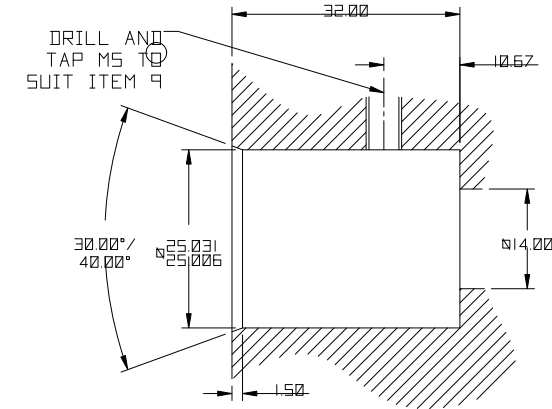

THREADED FLANGE MACHINING DETAILS.

TO SEAL USE ITEM 6

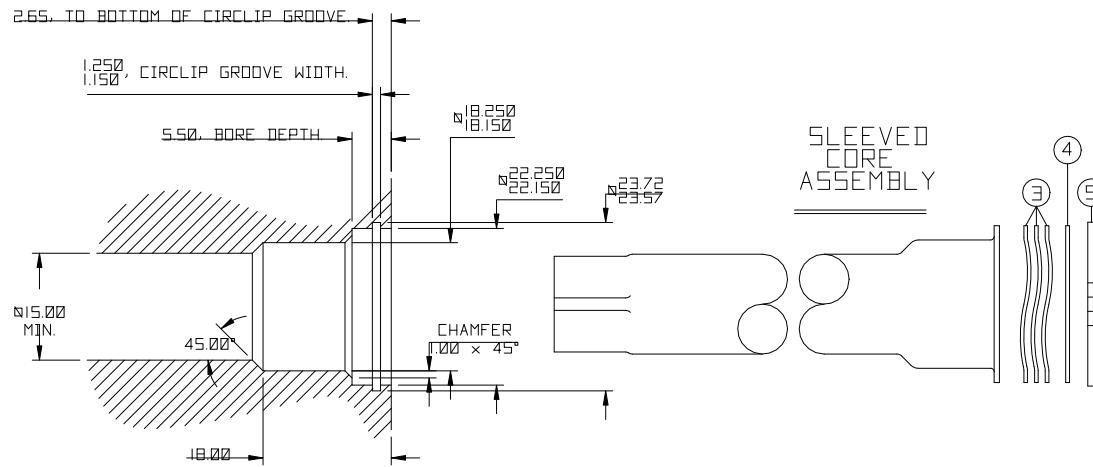
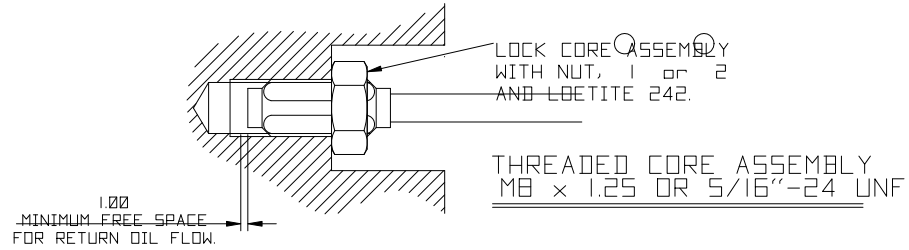
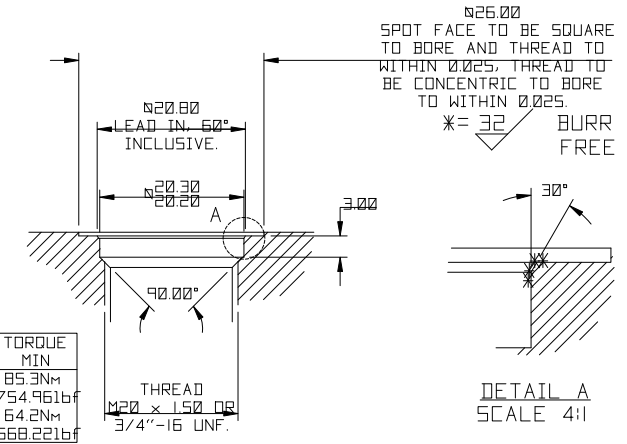

SCALE 1:1 UNLESS STATED	IF CONTROL DIMENSIONS (K) ARE SPECIFIED THEY ARE TO BE SUBJECT TO 100% INSPECTION OR STATISTICAL PROCESS CONTROL	D No ICT100 FIRST USED ON	MATERIAL -	TOLERANCES: IN-LINE WITH PENNY & GILES STANDARDS 33-501 SURFACE TEXTURE VALUES IN MICROMETRES (µ) TO BS1134PT2. ALL MACHINED SURFACES TO BE 1.6	TITLE SUGGESTED ICT100 INSTALLATION DETAILS AND INSTALLATION KIT 'L' TEMPERATURE RANGE	PENNY + GILES	A 3
THIRD ANGLE PROJECTION TO BS 8888	REF.	FINISH -	ANGULAR ±1° LINEAR 0.05mm +/- 0.05mm 0.10mm +/- 0.08mm 0.20mm +/- 0.10mm 0.30mm +/- 0.20mm	ALL SCREW THREADS TO BS3643 PT.2: EXTERNAL CLASS: 6g INTERNAL CLASS: 6H BREAK EDGE 0.05 - 0.15mm FILLET RADS 0.1 - 0.3mm	PART NUMBER: A1207803	SHT 1 OF 1 SHTS	