

Precision Purpose CTL-Z series

Ultra small AC current sensor for precise measurement for PCB mounting vertically



Model CTL-5-V-Z

- [Features]**
- Optimum for secondary CT of high capacity 5A output type (Micro CT)
 - Possible to apply until 20A max for power meter CT build in type
 - Excellent characteristic with adoption of permalloy core of high magnetic permeability
 - Possible to interface with electrical circuit directly by 800:1 high current ratio
 - Possible to mount on PCB with ultra small size of $\phi 5$ aperture and mass 8g.

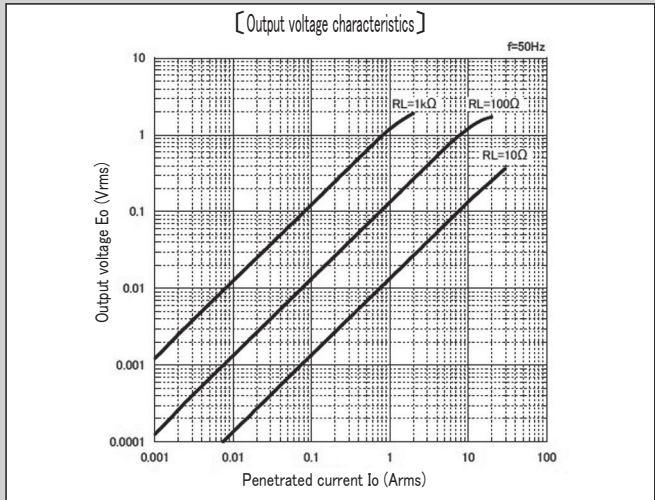
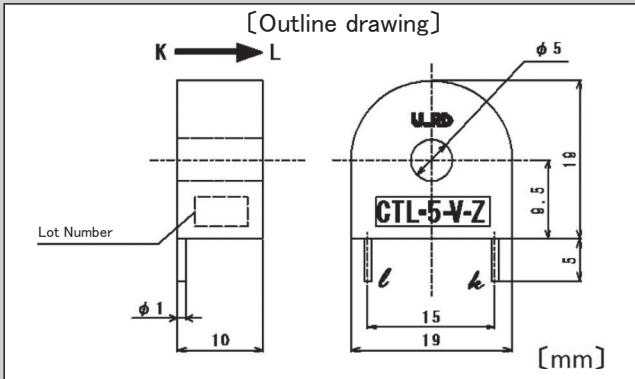

[Specification] Ta=25°C

Model	CTL-5-V-Z
Primary current	1mA ~ 20Arms (50 / 60Hz)、 $R_L \leq 10 \Omega$
Maximum primary current	80Arms continuous
Saturation limited current	30Arms (50 / 60Hz)、 $R_L \leq 1 \Omega$
Output characteristics	Refer "Output voltage characteristics"
Linearity	Refer "Coupling efficiency [K] characteristics" (Use the flat range of [K] characteristic in the application as the linear sensor)
Secondary windings (n)	800 ± 2 turn
Secondary windings resistance	36 Ω (reference)
Withstand voltage	AC2000V(50/60Hz), 1min(between aperture and output terminal in a lump)
Insulation resistance	DC500V, $\geq 100M \Omega$ (between aperture and output terminal in a lump)
Operating temperature	-20°C ~ +75°C, $\leq 90\%$, no condensation, for indoor assembly, free direction for setting
Storage temperature	-30°C ~ +90°C, $\leq 90\%$, no condensation
Structure	PBT plastic case, potted by epoxy on one side
Output terminal	$\phi 1.0 \times 5 \text{ l}$ (hard copper pins), gold plating
Mass	approximately 8g

Remark (1) Output voltage is changed by the penetrated current/load resistor/[K] characteristic and so on. Please set up the condition for use with careful investigation of each characteristic

(2) Please use with enough margin if the range of coupling efficiency $[K] \leq 0.9$, because it is the range to happen the individual difference.

(3) Opening the secondary during turn ON is hazardous and the cause of failure, because of generating high voltage

(4) Please be careful of CT heating in case to use with high frequency, although this CT is basically used at 50/60Hz.

